

Caldera Tech Series

24K Btu/h Single-Zone Heat Pump System

Outdoor Model: ML24HP230CALH-O

Indoor Model: ML24HP230CALH-I



Submittal Data Sheet	
Location:	Approval:
Engineer:	Date:
Submitted to:	Construction:
Submitted by:	Unit #:
Reference:	Drawing #:



INDOOR SPECIFICATION		
Indoor Air Flow (Turbo/H/M/L/Si) (CFM)	812.3 / 618.0 / 412.0 / 317.8 / /	
Indoor Noise Level (Turbo/H/M/L/Si) (dBA)	54.5/43.5/38.5/27/16	
Dimension (W×D×H)	inch	46.85x11.02x14.61
	mm	1190x280x371
Package (W×D×H)	inch	50.39x14.17x17.91
	mm	1280x360x455
Net/Gross Weight	lbs	43.65/55.56
	kg	19.8/25.2

OUTDOOR SPECIFICATION		
Compressor Type	ROTARY	
Compressor Model	KTM240D46UKT2	
Refrigerant	R454B	
Refrigerant Oil Charge(mL)	620	
Refrigerant Oil	VG74	
Outdoor Air Flow (Max) (CFM)	2235.3	
Outdoor Noise Level (dBA)	61.5	
Dimension (W×D×H)	inch	37.24 x 16.14 x 31.89
	mm	946.0×410.0×810.0
Package (W×D×H)	inch	42.91 x 19.68 x 34.84
	mm	1090×500×885
Net/Gross Weight	lbs	130.29/141.31
	kg	59.1/64.1

EFFICIENCY			
Cooling		Heating	
SEER2	21	HSPF2-4	13.5
EER2	13.0	COP	3.42

PERFORMANCE of Cooling	
Cooling (Btu/hr)	
Rated Capacity	24000
Min/Max Capacity	12600~27900
Moisture Removal(L/h)	2.7
Standard Operating Range(°F/°C)	-22~122(-30~50)
Conditions:	Indoor: 80°F DB/67°F WB Outdoor: 95°F DB/75°F WB

PERFORMANCE of Heating	
Heating (Btu/hr)	
1. @ 47°F Rated	29000
1. @ 47°F Min/Max Capacity	11800~29700
2. @ 17°F Rated	21000
3. @ 5°F Rated: Capacity / COP	24200/2.34
3. @ 5°F Max: Capacity	24200
Standard Operating Range(°F/°C)	-22~75(-30~24)
1. Conditions:	Indoor: 70°F DB/60°F WB Outdoor: 47°F DB/43°F WB
2. Conditions:	Indoor: 70°F DB/60°F WB Outdoor: 17°F DB/15°F WB
3. Conditions:	Indoor: 70°F DB/60°F WB Outdoor: 5°F DB/5°F WB

ELECTRICAL	
Power Supply	208/230V,60Hz,1Ph
System MCA	24.9
Connection Wiring	14#x4
System MOCP	25
Compressor RLA	15.0
Outdoor Fan Motor RLA	1.3
Outdoor Fan Motor W	120
Indoor Fan Motor RLA	1.3
Indoor Fan Motor W	58
System Power Input @ Cooling (W)	1846(940 ~ 2280)
System Power Input @ Heating (W)	2485(675 ~2570)
MCA: Min. circuit amps (A)	MOCP: Max. over current protection (A)
RLA: Rated load amps (A)	W: Fan motor rated output (W)

PIPING	
Throttle type(Indoor)	N/A
Throttle type(Outdoor)	EXV+Throttle valve
Liquid Size	9.52mm(3/8in)
Gas Size	15.9mm(5/8in)
Max. Piping Length(ft/m)	164.00(50)
Max. Height Difference(ft/m)	82.00(25)
Max. Pre-charged Length(ft/m)	24.6(7.5)
Refrigerant Pre-charged Amount(oz/g)	63.49(1.8)
Additional Charge of Refrigerant((oz/ft)/(g/m))	0.32(30)
Connection Method	Flared

Indoor Unit Dimension

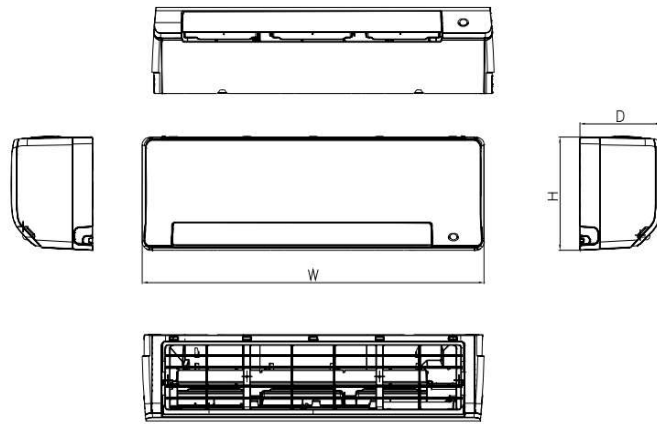

Capacity	Body Code	Unit	W	D	H
9k~12k	B	mm	848	230	300
		inch	33.39	9.06	11.81
18k~24k	C	mm	1017	242	319
		inch	40.04	9.53	12.56
24k~36k	D	mm	1190	280	371
		inch	46.85	11.02	14.61

Installation Instruction

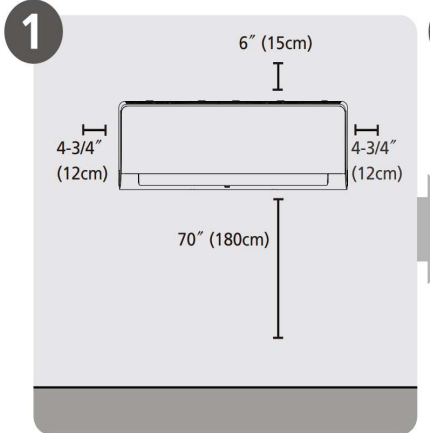

Select Installation Location

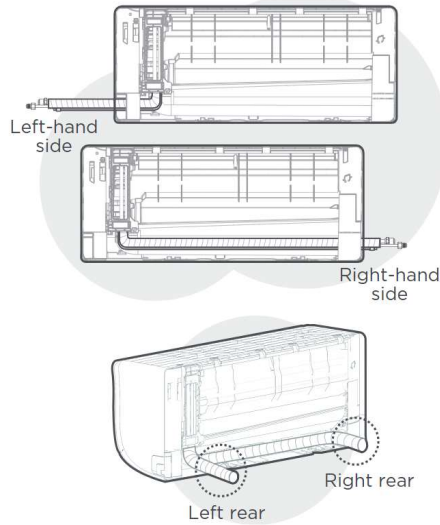

NOTE:
Based on the position of the wall hole relative to the mounting plate, choose the side from which the piping will exit the unit. You have four options for the exit direction of the piping.

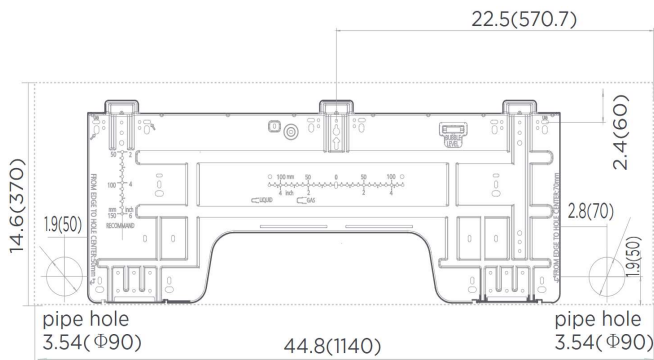

NOTE:
When the gas side connective pipe is Φ (5/8in)16mm or more, the wall hole should be (3-1/2in)90mm.

Outdoor Unit Dimension

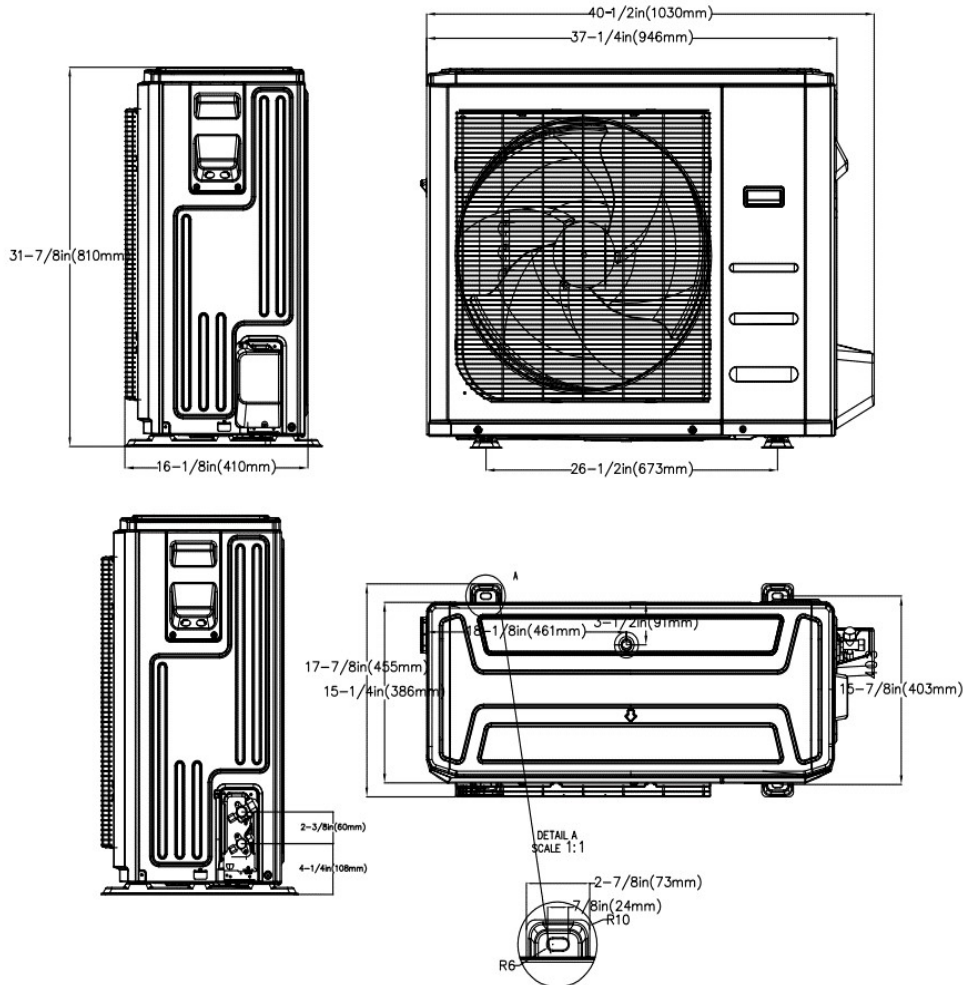

Installation Instruction

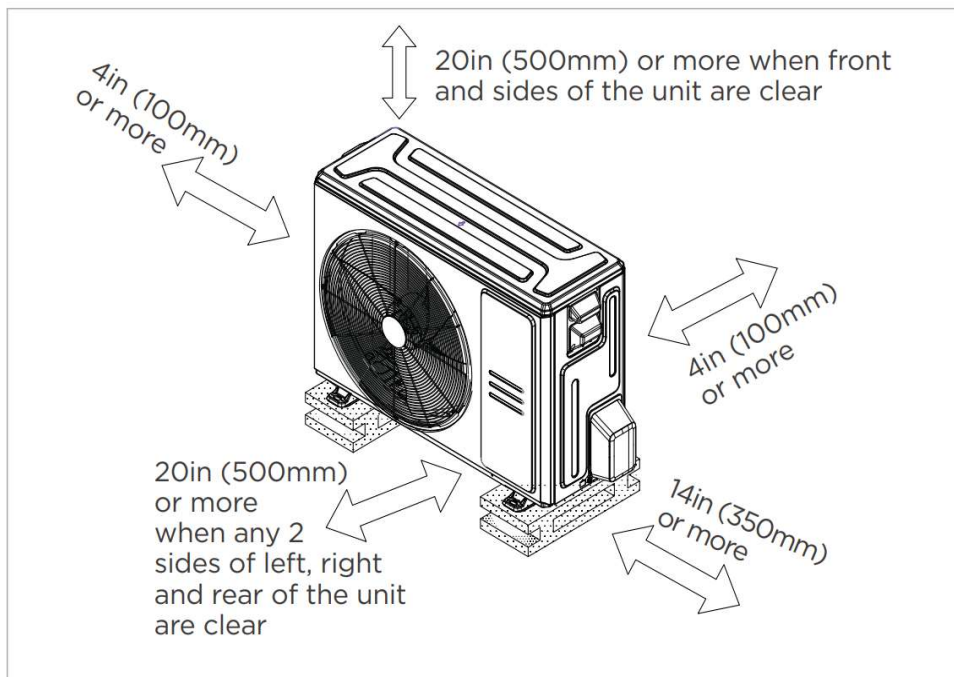

Meets all spatial requirements shown in Installation Clearance Requirements above.

FEATURES

- Intelligent eye
- Easy maintenance design
- Indoor unit TU1 copper coil
- Humidity control
- 1~100% fan speed setting
- WiFi capability: through WiFi dongle or wired controller with built-in WiFi
- OTA(by using WiFi dongle)
- Multiple control options available:
 - Two way communication wired controller:120N(X6)
 - Two way communication wired controller with built-in WiFi:120N(X6W)
 - Infrared wired controller: 120L
 - Wireless remote controller
 - Third-Party 24V Thermostat*

*24V interface is required.