

# Nexus Ultra Heat Series

18K Btu/h Single-Zone Heat Pump System

Outdoor Model: ML18HP230NEXH-O

Indoor Model: ML18HP230NEX-I



Submittal Data Sheet	
Location:	Approval:
Engineer:	Date:
Submitted to:	Construction:
Submitted by:	Unit #:
Reference:	Drawing #:



INDOOR SPECIFICATION		
Indoor Air Flow (Turbo/H/M/L/Si) (CFM)	759.3 / 500.3 / 441.4 / 370.8 / /	
Indoor Noise Level (Turbo/H/M/L/Si) (dBA)	54.5/45.0/40.0/24.5/20.0	
Dimension (WxDxH)	inch	42.60 x 9.21 x 13.27
	mm	1082.0x234.0x337.0
Package (WxDxH)	inch	45.47 x 16.34 x 12.40
	mm	1155x415x315
Net/Gross Weight	lbs	30.42/39.68
	kg	13.8/18

OUTDOOR SPECIFICATION		
Compressor Type	ROTARY	
Compressor Model	KTM240D46UKT2	
Refrigerant	R454B	
Refrigerant Oil Charge(mL)	620	
Refrigerant Oil	VG74	
Outdoor Air Flow (Max) (CFM)	1764.7	
Outdoor Noise Level (dBA)	59.0	
Dimension (WxDxH)	inch	35.04 x 13.46 x 26.50
	mm	890.0x342.0x673.0
Package (WxDxH)	inch	39.17 x 15.67 x 29.13
	mm	995x398x740
Net/Gross Weight	lbs	99.87/107.80
	kg	45.3/48.9

EFFICIENCY			
Cooling		Heating	
SEER2	21.7	HSPF2-4	10.8
EER2	13.0	COP	3.54

PERFORMANCE of Cooling	
Cooling (Btu/hr)	
Rated Capacity	18000
Min/Max Capacity	8400~20200
Moisture Removal(L/h)	1.8
Standard Operating Range(°F/°C)	-22~122(-30~50)
Conditions:	Indoor: 80°F DB/67°F WB Outdoor: 95°F DB/75°F WB

PERFORMANCE of Heating	
Heating (Btu/hr)	
1. @ 47°F Rated	18000
1. @ 47°F Min/Max Capacity	10300~23000
2. @ 17°F Rated	14400
3. @ 5°F Rated: Capacity / COP	18000/2.00
3. @ 5°F Max: Capacity	18000
Standard Operating Range(°F/°C)	-22~75(-30~24)
1. Conditions:	Indoor: 70°F DB/60°F WB Outdoor: 47°F DB/43°F WB
2. Conditions:	Indoor: 70°F DB/60°F WB Outdoor: 17°F DB/15°F WB
3. Conditions	Indoor: 70°F DB/60°F WB Outdoor: 5°F DB/5°F WB

ELECTRICAL	
Power Supply	208/230V,60Hz,1Ph
System MCA	19.0
Connection Wiring	14#x4
System MOCP	20
Compressor RLA	11.7
Outdoor Fan Motor RLA	0.9
Outdoor Fan Motor W	80
Indoor Fan Motor RLA	0.8
Indoor Fan Motor W	58
System Power Input @ Cooling (W)	1384(360 ~ 1860)
System Power Input @ Heating (W)	1490(650 ~1740)
MCA: Min. circuit amps (A)	MOCP: Max. over current protection (A)
RLA: Rated load amps (A)	W: Fan motor rated output (W)

PIPING	
Throttle type(Indoor)	N/A
Throttle type(Outdoor)	EXV+Throttle valve
Liquid Size	6.35mm(1/4in)
Gas Size	12.7mm(1/2in)
Max. Piping Length(ft/m)	98.40(30)
Max. Height Difference(ft/m)	65.60(20)
Max. Pre-charged Length(ft/m)	24.6(7.5)
Refrigerant Pre-charged Amount(oz/g)	55.38(1.57)
Additional Charge of Refrigerant(oz/ft)/(g/m)	0.16(15)
Connection Method	Flared

## Indoor Unit Dimension

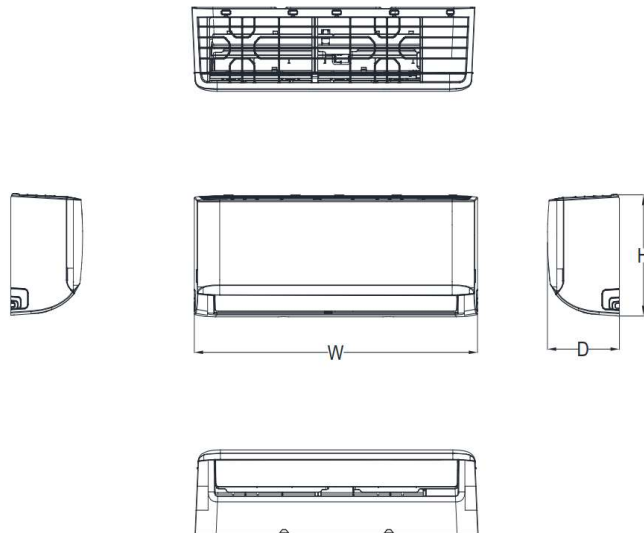

Capacity	Body Code	W(inch/mm)	D(mm/inch)	H(mm/inch)
6K~9K	A	28-3/4in /729mm	7-7/8in /200mm	11-1/2in /292mm
9K~12K	B	31-5/8in /802mm	7-7/8in /200mm	11-5/8in /295mm
18K	C	38-1/4in /971mm	9in/228mm	12-5/8in /321mm
18K~24K	D	42-5/8in /1082mm	9-1/4in/234mm	13-1/4in /337mm
30K~36K	F	49-5/8in /1259mm	11-1/8in/283mm	14-1/4in /362mm

## Installation Instruction

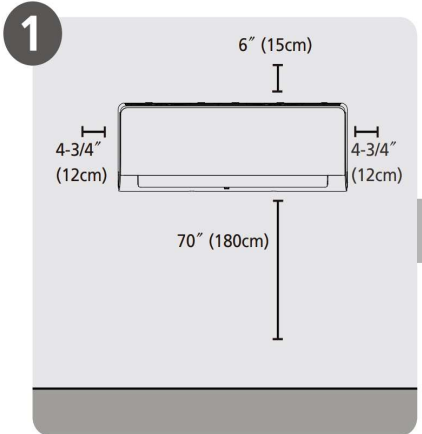

**Select Installation Location**

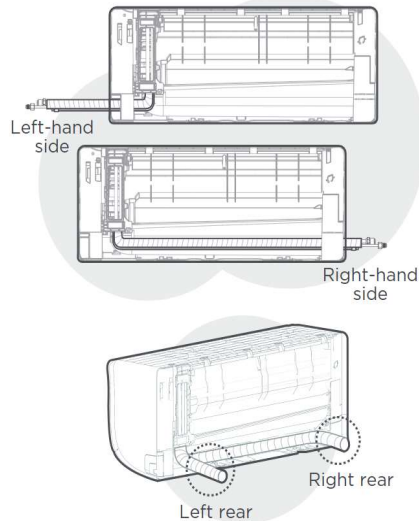

**NOTE:**  
Based on the position of the wall hole relative to the mounting plate, choose the side from which the piping will exit the unit. You have four options for the exit direction of the piping.

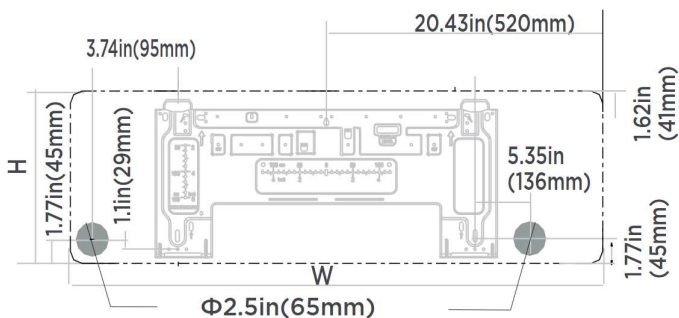

**Indoor unit dimensions(WxH):**  
38.2in(971mm)x12.6in(321mm)

**NOTE:**  
When the gas side connective pipe is  $\Phi$  (5/8in)16mm or more, the wall hole should be (3-1/2in)90mm.

Outdoor Unit Dimension

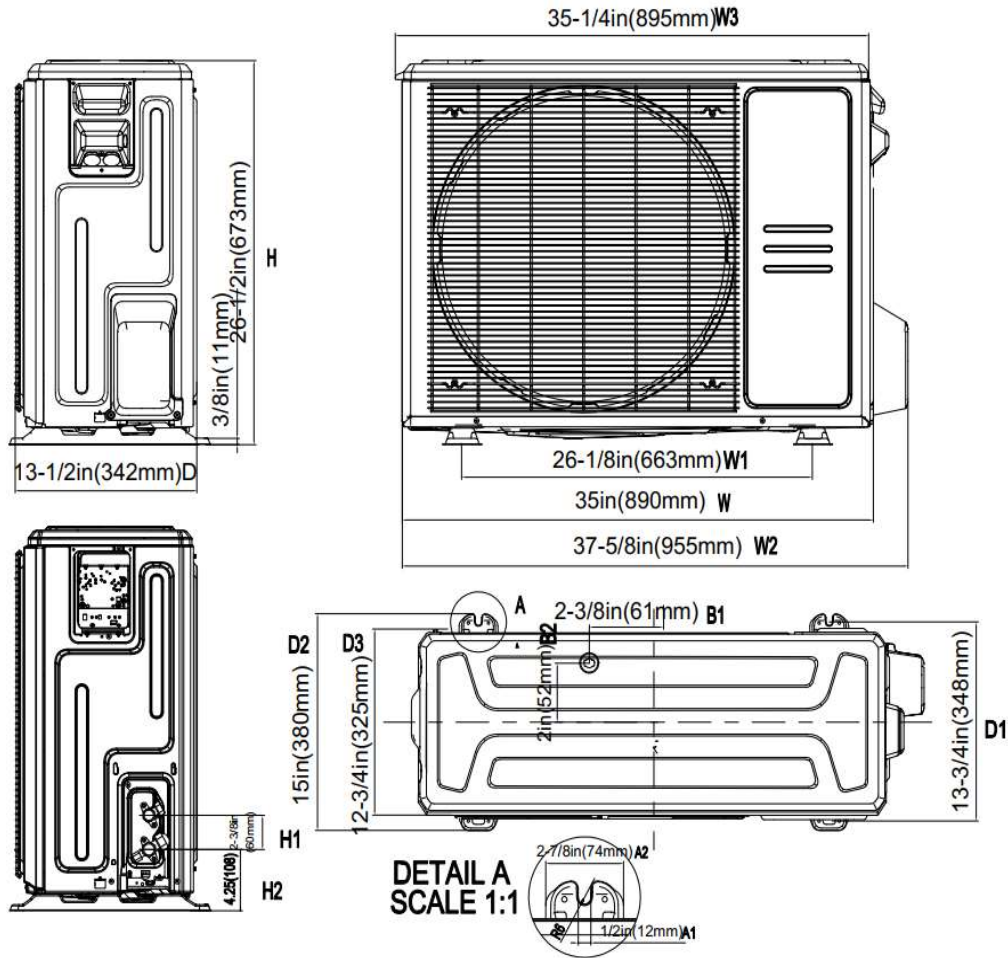

Installation Instruction

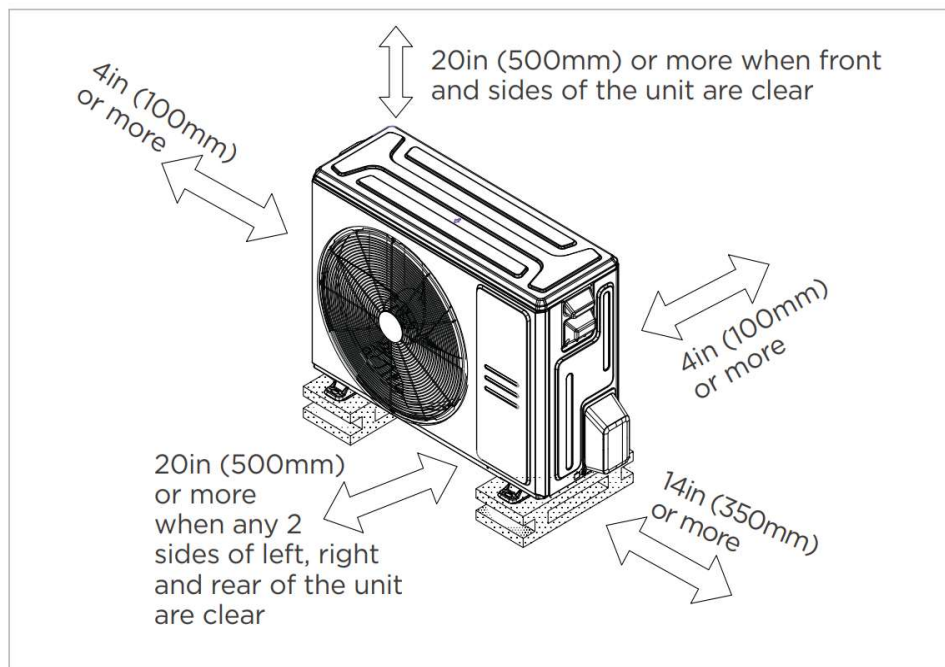

Meets all spatial requirements shown in Installation Clearance Requirements above.

## FEATURES

- Indoor unit TU1 copper coil
- Humidity control
- 1~100% fan speed setting
- WiFi capability: through WiFi dongle or wired controller with built-in WiFi
- OTA(by using WiFi dongle)
- Multiple control options available:
  - Two way communication wired controller:120N(X6)
  - Two way communication wired controller with built-in WiFi:120N(X6W)
  - Infrared wired controller: 120L
  - Wireless remote controller
  - Third-Party 24V Thermostat\*

\*24V interface is required.